



Reference Manual

D VA 3120

Dual Analog Video Distribution Amplifier

Series 3000
MiniModules

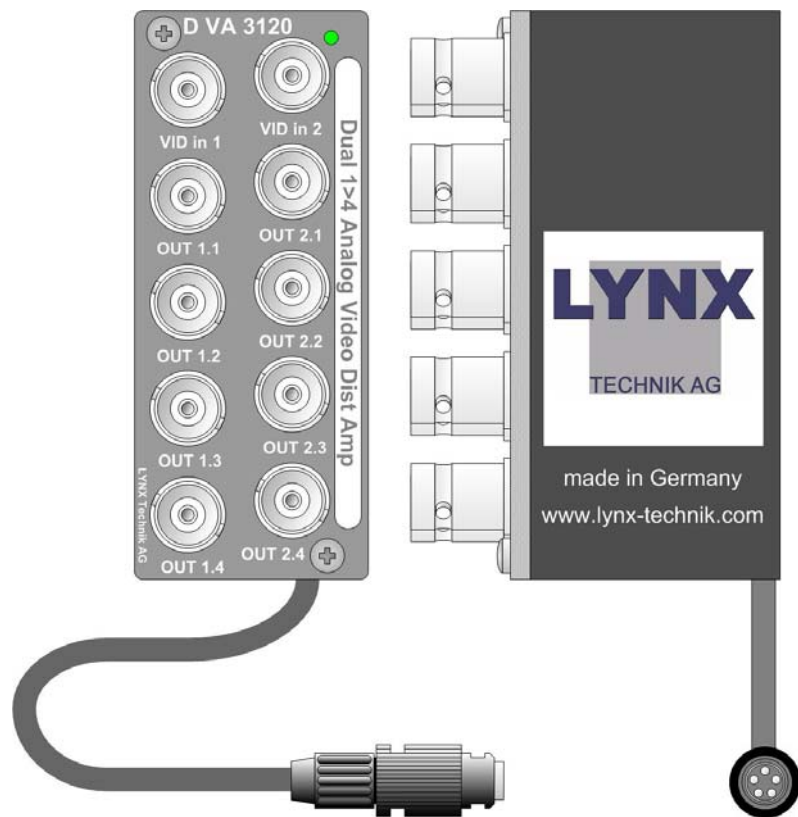

© LYNX Technik AG
Brunnenweg 3
64331 Weiterstadt
Germany
www.lynx-technik.com

Information in this document is subject to change without notice. No part of this document may be reproduced or transmitted in any form or by any means, electronic or mechanical for any purpose, without express written permission of LYNX Technik AG.

LYNX Technik AG may have patents, patent applications, trademarks, copyrights or other intellectual property rights covering the subject matter in this document. Except as expressly written by LYNX Technik AG, the furnishing of this document does not give you any license to patents, trademarks, copyrights or other intellectual property of LYNX Technik AG or any of its affiliates.

© LYNX Technik AG 2002 all rights reserved

Warranty

LYNX Technik AG warrants that the product will be free from defects in materials and workmanship for a period of two (2) years from the date of shipment. If this product proves defective during the warranty period, LYNX Technik AG at its option will either repair the defective product without charge for parts and labor, or will provide a replacement in exchange for the defective product.

In order to obtain service under this warranty, customer must notify LYNX Technik of the defect before expiration of the warranty period and make suitable arrangements for the performance of service. Customer shall be responsible for packaging and shipping the defective product to the service center designated by LYNX Technik, with shipping charges prepaid. LYNX Technik shall pay for the return of the product to the customer if the shipment is within the country which the LYNX Technik service center is located. Customer shall be responsible for payment of all shipping charges, duties, taxes and any other charges for products returned to any other locations.

This warranty shall not apply to any defect, failure, or damage caused by improper use or improper or inadequate maintenance and care. LYNX Technik shall not be obligated to furnish service under this warranty a) to repair damage resulting from attempts by personnel other than LYNX Technik representatives to install, repair or service the product; b) to repair damage resulting from improper use or connection to incompatible equipment; c) to repair any damage or malfunction caused by the use of non LYNX Technik supplies; or d) to service a product which has been modified or integrated with other products when the effect of such modification or integration increases the time or difficulty servicing the product.

THIS WARRANTY IS GIVEN BY LYNX TECHNIK WITH RESPECT TO THIS PRODUCT IN LIEU OF ANY OTHER WARRANTIES, EXPRESS OR IMPLIED. LYNX TECHNIK AND ITS VENDORS DISCLAIM ANY IMPLIED WARRANTIES OF MERCHANTABILITY OR FITNESS FOR A PARTICULAR PURPOSE. LYNX TECHNIK`S RESPONSIBILITY TO REPAIR AND REPLACE DEFECTIVE PRODUCTS IS THE SOLE AND EXCLUSIVE REMEDY PROVIDED TO THE CUSTOMER FOR BREACH OF THIS WARRANTY. LYNX TECHNIK AND ITS VENDORS WILL NOT BE LIABLE FOR ANY INDIRECT, SPECIAL, INCIDENTAL, OR CONSEQUENTIAL DAMAGES IRRESPECTIVE OF WHETHER LYNX TECHNIK OR THE VENDOR HAS ADVANCE NOTICE OF THE POSSIBILITY OF SUCH DAMAGES.

Regulatory information

Europe

Declaration of Conformity

We	LYNX Technik AG Brunnenweg 3 D-64331 Weiterstadt Germany
<i>Declare under our sole responsibility that the product</i>	
TYPE: D VA 3120	
<i>To which this declaration relates is in conformity with the following standards (environments E1-E3):</i>	
EN 55103-1 /1996	
EN 55103-2 /1996	
EN 60950 /2001	
<i>following the provisions of 89/336/EEC and 73/23/EEC directives.</i>	
	Winfried Deckelmann
Weiterstadt, November 2003	
<i>Place and date of issue</i>	<i>Legal Signature</i>

USA

FCC 47 Part 15

This device complies with part 15 of the FCC Rules. Operation is subject to the following two conditions: (1) This device may not cause harmful interference, and (2) this device must accept any interference received, including interference that may cause undesired operation.

Note: This equipment has been tested and found to comply with the limits for a Class A digital device, pursuant to the part 15 of the FCC Rules. These limits are designed to provide reasonable protection against harmful interference when the equipment is operated in a commercial environment. This equipment generates, uses, and can radiate radio frequency energy and, if not installed and used in accordance with the instruction manual, may cause harmful interference to radio communications. Operation of this equipment in a residential area is likely to cause harmful interference in which case the user will be required to correct the interference at his own expense

Contents

Warranty	3
Regulatory information	4
Europe.....	4
Declaration of Conformity	4
USA	4
FCC 47 Part 15.....	4
Contents	5
Getting Started	7
Packaging.....	7
Product Description	7
Functional Diagram	8
Module Layout	8
Connections	10
Video Connections.....	10
Power Connections	11
DC Power Connector	11
Installation	12
Mechanical.....	12
Stand Alone Operation	12
Multiple Units.....	13
Electrical Installation.....	14
Stand Alone Operation	14
Multiple Units.....	15
Settings and Control	15
Switch Settings	15
Switch Function Detail	16
Factory Preset Condition.....	16
Adjustment Procedures.....	17
Set Dual 1:4 or 1:8 mode	18
Set Video Gain.....	19
Set Equalization.....	20
Set Unity Gain.....	21
Set Unity Equalization	22
Auto Store	22
Alarm/LED Status Indicators	23
Channel Condition Indicators	23
Front Panel Alarm Indicator	23
Locate Function.....	24
Specifications (D VA 3120)	25
Available Options	26
Parts List	27
Service	27
Contact Information	28

This Page is intentionally left blank

Getting Started

Packaging

The shipping carton and packaging materials provide protection for the module during transit. Please retain the shipping cartons in case subsequent shipping of the product becomes necessary.

Product Description

The D VA 3120 is a high quality analog video distribution amplifier designed primarily for broadcast and professional applications.

Flexible configurations allow the D VA 3120 to be used in dual 1 to 4 applications or 1 to 8 applications with independent gain and equalization adjustment for each channel. The module is microprocessor controlled and configuration, gain level and equalization are set using local controls included on the module. All settings are stored in internal flash ram. Presence detection is provided via status LEDs and a front side alarm LED is also provided.

The D VA 3120 is part of the 3000 series of MiniModules, which offer high quality, modularity and flexibility in a very small form factor ideal for applications where space is at a premium.

The modules can be used either stand alone using the optional power supply brick, or as part of a tightly integrated space saving system where up to 10 MiniModules can be mounted utilizing the optional LYNX R FR 3005/3010 rack housing. This includes integrated power supply and optional remote control interfaces.

Functional Diagram

Figure 1 below is the basic functional diagram for the D VA 3120 MiniModule.

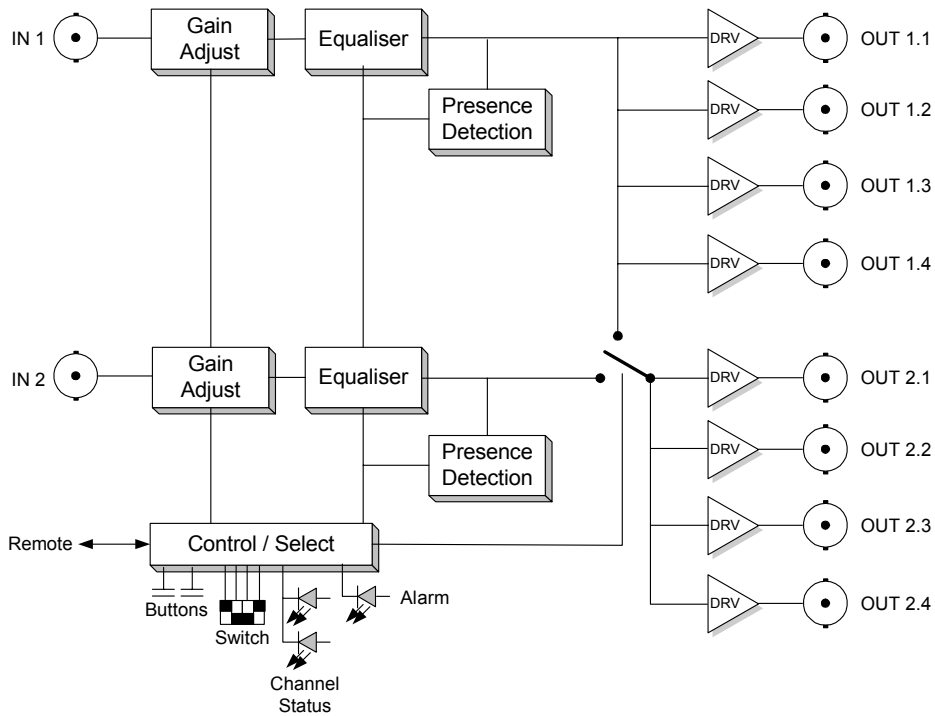

Figure 1- D VA 3120 Functional Diagram

Module Layout

Figure 2 shows the physical layout of the D VA 3120 MiniModule. Video I/O is made through standard BNC video connectors. Module configuration is set via a small dip-switch and push buttons located behind a small access hole in the bottom of the module. When used in single mode (1x1:8) **IN 1** is used as the input signal.

If the module is being used in a stand alone application then the optional power supply (R PS 3001 E, R PS 3001 U or R PS 3001-3) is required to power the module (not shown)

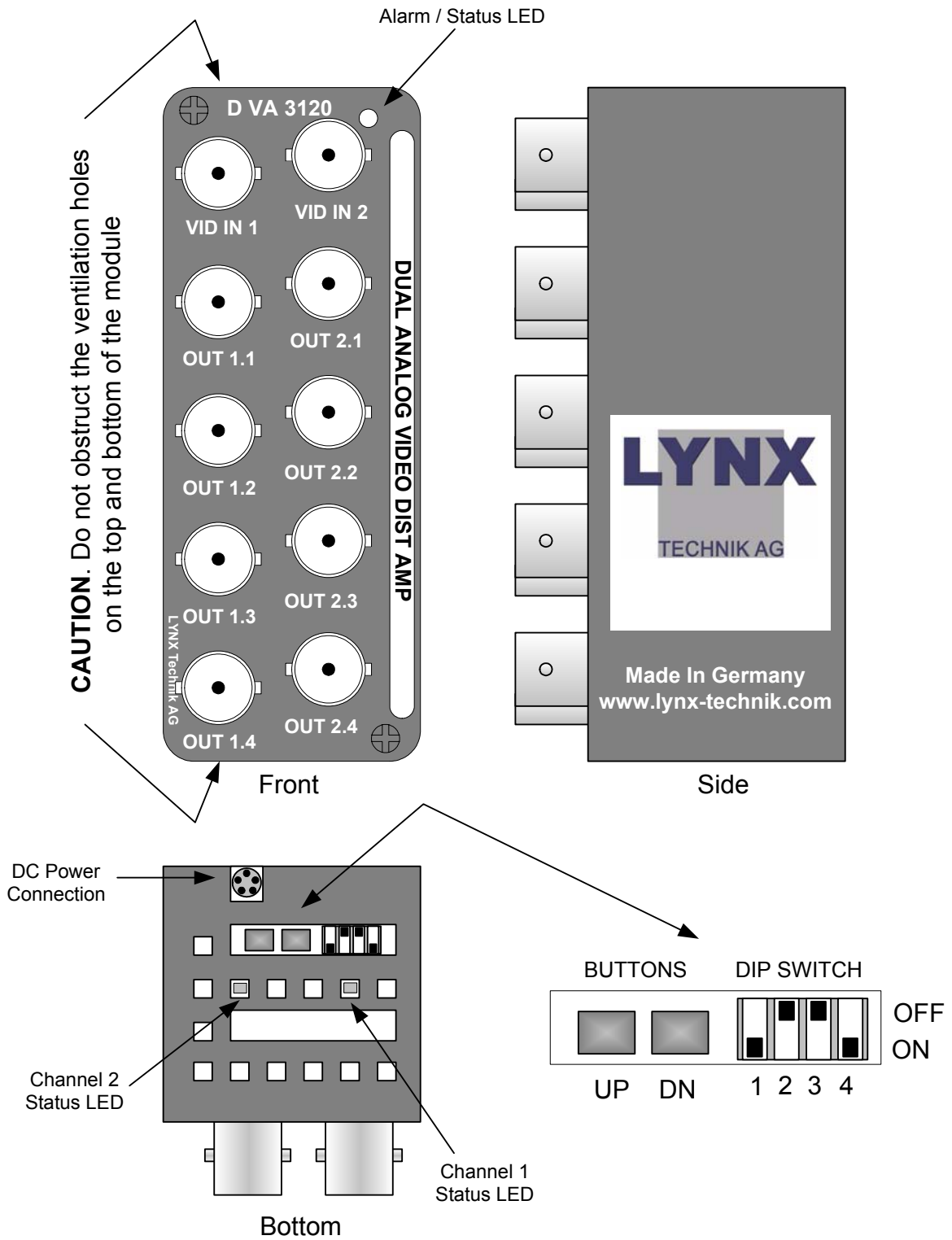

Figure 2 – Module Layout

Connections

Video Connections

The D VA 3120 MiniModule is configured with standard 75 Ohm BNC connectors. Connection is self-explanatory. We recommend the use of high quality video cable to reduce the risk of interference or errors due to excessive cable attenuation.

Note. Due to the compact design of the module it will be necessary to use a connection tool to secure the BNC video connectors to the module.

Power Connections

If using the module in a stand-alone application use the separate R PS 3001 E (for Europe), R PS 3001 U (USA) power brick option or the R PS 3001-3 desk power supply.

DC Power Connector

The MiniModule has a captive power lead fitted to the module, with a male 5 pin locking bayonet connector. This connection provides DC power and also data connectivity to the module. Connector wiring is shown below.

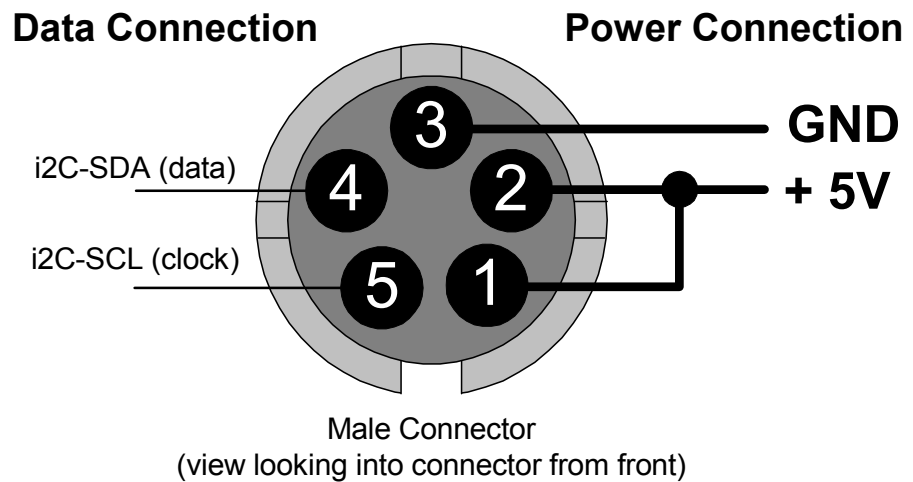

Caution

Only use the optional LYNX R PS power modules. Ensure the 5-pin power connector is locked securely in place.

Installation

Mechanical

Stand Alone Operation

The D VA 3120 MiniModule can be used in a stand alone application. There are two options for the use of the module in this way.

- a) Using the R FR 3005 Rack Frame 1 option. This allows up to any 10 of the MiniModules to be secured onto a rack frame assembly for 19 inch rack mounting. This keeps the modules secured, organized and out of the way. The R PS 3001 power brick option or the R FR 3010 option is required to power each module. Please refer to the R FR 3005 Reference Manual supplied with this option for more details.
- b) Single Use. The MiniModule can be powered independently with the R PS 3001 option and used in any location where this functionality is required.



Caution. Care needs to be taken when using the module in this way, as it is not physically secured. Keep the module away from the floor to avoid the risk of someone stepping or tripping on the unit, and locate the unit away from excessive sources of heat and any sources or moisture.

If using more than one MiniModule in any installation, the R FR 3005/3010 Rack frame combination is highly recommended.

Multiple Units

Most applications will require more than one MiniModule, which can include any of the available Series 3000 MiniModule product range. There are two options for mounting multiple units.

- a) Using the R FR 3005 Rack Frame option. This allows up to any 10 of the MiniModules to be secured onto a rack frame assembly for 19 inch rack mounting. The R PS 3001 power brick option or the R FR 3010 option is required to power each module. Please refer to the R FR 3005 Reference Manual for more details.

- b) Using the R FR 3010 Rack frame extension option. Can be combined with the R FR 3005 Rack frame option. Each module plugs into a connection bus, which provides common power for all modules. (no R PS external power supplies are needed). Remote control and status monitoring of all modules is possible with the addition of the R CT 5020 rack controller and R CT 5030 master controller options. Please refer to the respective reference manuals for these options for details of mechanical installation.

The very small size and density of the MiniModules combined with the available rack frame options allows the addition of a complex and custom signal distribution system without taking any additional front rack space. The rack frames are designed for installation in the back of 19-inch racks where there is normally plenty of available space. Ideal for mobile truck installations and facility expansions where space is at a premium.

Electrical Installation.

Stand Alone Operation

The MiniModule requires the R PS 3001 power brick option for stand-alone operation. Three versions are available R PS 3001 E for European markets, R PS 3001 U for the US markets or the universal R PS 3001-3 desk power supply . Please ensure you have the correct power option for your region. The connection to the module is made with a small 5-pin connector, which has a twist bayonet securing system. Please make sure the connection is solid and locked in place. A strain relief is included within the module to prevent excessive strain on the connection.

Signal connections should be made with care, please ensure connections are correct and compatible equipment is feeding / receiving the signals from the module or damage can result.



Caution. Only use the optional Lynx R PS 3001 power modules. Ensure the 5-pin power connector is locked securely in place.



Caution. Care needs to be taken when using the module in this way, if it is not physically secured. Keep the module away from the floor to avoid the risk of someone stepping or tripping on the unit, and locate the unit away from excessive sources of heat and any sources or moisture.

Multiple Units

When installing multiple MiniModule units it is recommended you use the R FR 3005 Rack Frame 1 and/or R FR 3010 Rack Frame 2 options. Please refer to the documentation supplied with these options for details on electrical installation.

Settings and Control

The D VA 3120 is configured via the integral 4-position dip-switch and push buttons.

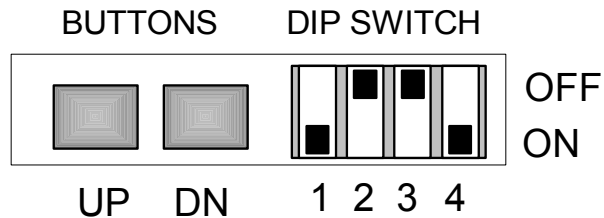

Switch Settings

Below the switch settings for the 4-position dip-switch are defined. Switch function is described in more detail after the table below.

Switch	Setting	Function
1	ON	Single 1:8 mode *
	OFF	Dual 1:4 mode
2	ON	Gain adjustment selected
	OFF	Equalizer adjustment selected
3	ON	Unity selected
	OFF	Unity not selected
4	ON	Channel 2 selected
	OFF	Channel 1 selected

*When in single mode the **IN 1** video input is used.

Switch Function Detail

The switches are used as part of an adjustment procedure and setting is not an implicit process. Please refer to the alignment procedure section for details on how to use the switches to set up the module. The information below simply describes function.

Dip Switch 1

This switch sets the configuration of the module. **ON** sets single 1:8 mode. **OFF** sets dual 1:4 mode.

Dip Switch 2

This switch selects the parameter for adjustment using the module push buttons. **ON** selects gain, **OFF** selects equalization.

Dip Switch 3

This switch sets unity gain / equalization for the module. **ON** selects unity, **OFF** allows for adjustment.

Dip Switch 4

This switch selects the channel for adjustment. **ON** selects channel 2, **OFF** selects channel 1.

Factory Preset Condition

The D VA 3120 is delivered preset for the following mode of operation:

Mode	2 x 1:4
Setting	Unity Gain, Unity Equalization

If this is the mode of operation required, then no adjustments are necessary.

Adjustment Procedures

The modules configuration and gain/EQ settings are set using combinations of the Dip Switch and the two push buttons located on the module edge.

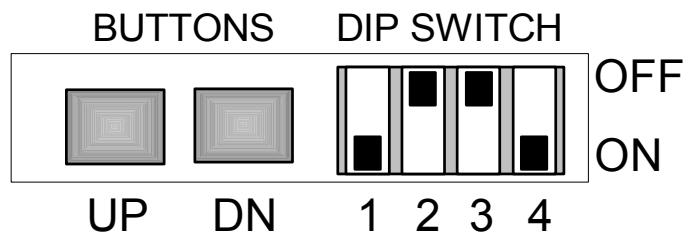

Setting functionality and calibration is interactive and not an implicit switch setting process. The adjustments are made through imbedded micro-controller and settings stored on internal flash ram. To simplify the configuration and setting of the module a series of procedures has been defined to make setting the module easier. These are:

- Set Dual 1:4 or 1:8 Mode
- Set Video Gain
- Set Equalization
- Set Unity Gain
- Set Unity Equalization

These procedures capture most things you would need to change or set on the module.

Set Dual 1:4 or 1:8 mode

The D VA 3120 module can be set to one of two preset modes of operation.

Dual 1:4 Mode. This is a simple 2 x 1 to 4 video amplifier. Independent channels passed through the amplifier providing four outputs for each input channel.

Single 1:8 Mode. This is a simple 1 x 1 to 8 Video amplifier. The signal on the **IN 1** input channel is passed through the amplifier providing eight outputs.

Use this procedure to select dual 1:4 or single 1:8 mode of operation.

1. Set Switch 1 to **ON** for 1:8 mode* or **OFF** for dual 1:4 mode
2. If 10 seconds pass with no further adjustment both channel status LEDs will flash yellow four times. This confirms setting has been written into flash ram and stored.

* When in 1: 8 mode the IN 2 channel indicator will go out.

Note. Diagram only shown for switch location reference not actual settings

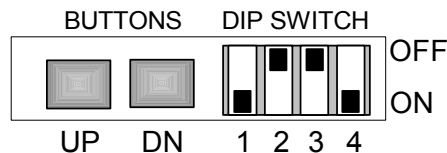

Set Video Gain

Use this procedure to set the video gain of the module.

1. Set Switch 1 to desired mode of operation **ON** for 1:8 mode or **OFF** for dual 1:4 mode
2. Set Switch 2 [*Gain / Equalization select*] to **ON**
3. Set Switch 3 [*Set Unity*] to **OFF**
4. Set switch 4 [*select input channel*] to select the channel to be adjusted **ON** for **IN 2** and **OFF** for **IN 1*** (respective LED will flash yellow once indicating selected channel)
5. Push either the **UP** or **DN** push buttons to make the necessary gain adjustment for the selected channel.
6. If using dual mode, set switch 4 to select the second channel and repeat 5 above.
7. If 10 seconds pass with no further adjustments being made both channel status LEDs will flash yellow four times. This confirms settings have been written into flash ram and stored.

* This switch is only used / functional when the module is configured for dual 1:4 mode of operation. If 1: 8 mode of operation is selected with switch 1, then the IN1 connection is used by default.

Note. Diagram only shown for switch location reference not actual settings

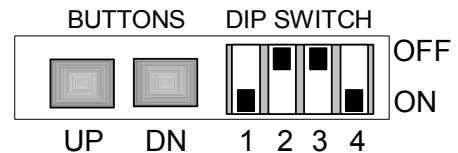

Set Equalization

Use this procedure to set the cable equalization for the module

1. Set Switch 1 to desired mode of operation **ON** for 1:8 mode or **OFF** for dual 1:4 mode
2. Set Switch 2 [*Gain / Equalization select*] to **OFF**
3. Set Switch 3 [*Set Unity*] to **OFF**
4. Set switch 4 [*select input channel*] to select the channel to be adjusted **ON** for **IN 2** and **OFF** for **IN 1*** (respective LED will flash yellow once indicating selected channel)
5. Push either the **UP** or **DN** push buttons to make the necessary equalization adjustment for the selected channel.
6. If using dual mode, set switch 4 to select the second channel and repeat 5 above.
7. If 10 seconds pass with no further adjustments being made both channel status LEDs will flash yellow four times. This confirms settings have been written into flash ram and stored.

* This switch is only used / functional when the module is configured for dual 1:4 mode of operation. If 1: 8 mode of operation is selected with switch 1, then the IN1 connection is used by default.

Note. Diagram only shown for switch location reference not actual settings

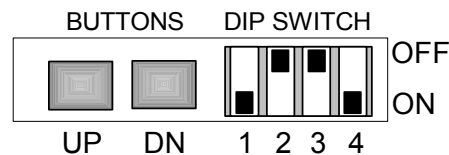

Set Unity Gain

Use the following procedure to set unity gain for the module

1. Set Switch 1 to desired mode of operation **ON** for 1:8 mode or **OFF** for dual 1:4 mode
2. Set Switch 2 [*Gain / Equalization select*] to **ON**
3. Set Switch 3 [*Set Unity*] to **ON**
4. Set switch 4 [*Select input channel*] to select the channel to be adjusted to unity **ON** for **IN 2** and **OFF** for **IN 1*** (respective LED will flash yellow once indicating selected channel)
5. Press either the **UP** or **DN** push button once to set unity gain for the selected channel.
6. If using dual mode, set switch 4 to select the second channel and repeat 5 above.
7. If 10 seconds pass with no further adjustments being made both channel status LEDs will flash yellow four times. This confirms settings have been written into flash ram and stored.

* This switch is only used / functional when the module is configured for dual 1:4 mode of operation. If 1: 8 mode of operation is selected with switch 1, then the IN1 connection is used by default.

Note. Diagram only shown for switch location reference not actual settings

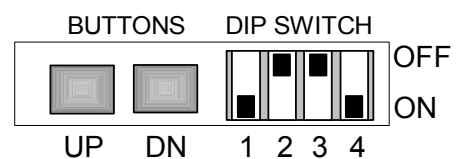

Set Unity Equalization

Use the following procedure to set unity equalization.

1. Set Switch 1 to desired mode of operation **ON** for 1:8 mode or **OFF** for dual 1:4 mode
2. Set Switch 2 [*Gain / Equalization select*] to **OFF**
3. Set Switch 3 [*Set Unity*] to **ON**
4. Set switch 4 [*Select input channel*] to select the channel to be adjusted to unity **ON** for **IN 2** and **OFF** for **IN 1*** (respective LED will flash yellow once indicating selected channel)
5. Press either the **UP** or **DN** push button once to set unity equalization for the selected channel.
6. If using dual mode, set switch 4 to select the second channel and repeat 5 above.
7. If 10 seconds pass with no further adjustments being made both channel status LEDs will flash yellow four times. This confirms settings have been written into flash ram and stored.

* This switch is only used / functional when the module is configured for dual 1:4 mode of operation. If 1: 8 mode of operation is selected with switch 1, then the IN1 connection is used by default.

Note. Diagram only shown for switch location reference not actual settings

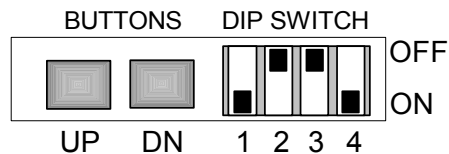

Auto Store

If no parameters are changed for 10 seconds then the current settings will be written into flash memory automatically, this can be seen by the channel condition LEDs flashing yellow four times.

Alarm/LED Status Indicators

The D VA 3120 module has built in LED indicators, which serve as alarm and status indication for the module. Function is described below.

The Indicators are found on the bottom of the module and can be seen through the access hole provided. (Figure 2)

Channel Condition Indicators

Two status LED` are provided on the module edge, one for each channel and can be seen through the access holes (figure 2)

LED Color	Indication
Green	Input Present
Yellow	Adjustment aid
Red	No input

Front Panel Alarm Indicator

There is also a single alarm LED on the front side of the module, which is designed for quick and easy indication of a problem condition in installations where visible access to the bottom of the module is not convenient.

LED Color	Indication
Green	Signal Present (in 2 x 1:4 mode green = both signals present)
Yellow	One input signal missing (in 2 x 1:4 only, LED not active in 1:8 mode)
Red	No input signal on active inputs

LED **OFF** indicates power is lost, or there is a power supply fault.

Locate Function

For large systems which have many modules in various locations we have added a utility which will help visually identify a module quickly. (When used in conjunction with the optional control system and software)

Once the module has been identified on the control system it is possible to initiate the "locate" function and flash the module LEDs yellow in the following continuous sequence.

3 short flashes.... Pause.... 3 short flashes ...

This uses the alarm LED located on the front of the module as well as any module edge LEDs that may be used in the module.

Use of the locate function will not interfere with the normal operation of the module.

For more details on this feature please check the documentation supplied with the controller software

Specifications (D VA 3120)

Inputs

Signal	2 x analog video, differential input 75 Ohm
Input Impedance	75 Ohm
Input level (max)	2V p-p
Return loss	> 31dB to 10MHz
Common Mode Rejection	> 65dB to 10 KHz
Connection	BNC, 75 Ohm

Outputs

Signal	8 x analog video return loss 46,5 dB to 10 MHz
Phase match	< 0.1° at 4.43 MHz
Response Variation	< 0.15dB to 8 loads
Connection	BNC, 75 Ohm
Adjustment range	-3,2 db / 3,6 db in 256 increments

Operating Modes

Dual	Dual Distribution Amplifier 1:4
Single	Single Distribution Amplifier 1:8

Performance

Frequency Response	+/- 0.1dB to 30 MHz, -3dB at 665 MHz
Differential Gain	<0.20%
Differential Phase	<0.15°
Hor./Vert. tilt	< 0.5%
Signal to noise ratio	>69 dB to 17MHz (RMS noise/700mV,unweighted)
Hum	< 0.5 mV
Gain	-3,2 db / 3,6 db in 256 increments
Cable Equalization	Up to 200m using Belden 8281
Control	Local settings (dip switch).
Status Monitoring (LED)	Signal presence, and front alarm

Electrical Specifications

Operating Voltage	+ 5VDC
Power Consumption	2.5 VA
Connection	DC input via 5 pin locking bayonet connector
Safety	IEC 60950/ EN 60950/VDE 0805

Mechanical

Size	85.5mm x 35.3mm x 38.7mm + connectors
Weight	250g

Ambient

Temperature	5°C to 35°C Maintaining specifications -20°C to +70°C Storage
Humidity	Max 80% non condensing

Supplied Accessories

Documentation	D VA 3120 Reference Manual and quick ref guide
---------------	--

Available Options

Below is a list of available options for the D VA 3120 MiniModule. Please refer to product brochures or our web site for more detailed information.

Model	Description
R PS 3001 E	External brick power supply module for Series 3000 MiniModules. European market version. 100-240 VAC input, +5V DC output.
R PS 3001 U	External brick power supply module for Series 3000 MiniModules. USA market version. 110-240 VAC input, +5V DC output.
R PS 3001-3	External desk power supply module for Series 3000 MiniModules. 110-240 VAC input, +5V DC output.
R FR 3004	Mounting support for up to 4 MiniModules
R FR 3005	Rack Frame 1. This is a basic 19 inch rack mountable frame which can accommodate 10 MiniModules with power bricks R PS 1 or can be extended with the R FR 3010.
R FR 3010	Rack Frame 2. This is a card cage with integrated central power supply, optional redundant power supply and optional controller, which can accommodate 10 MiniModules. Can be combined with R FR 3005
R PS C15	1.5m cable extension to connect one MiniModule to R FR 3010
R PS C25	2.5m cable extension to connect one MiniModule to R FR 3010
R PS 3010	Redundant power supply for the R FR 3010 card cage
R CT 5020	Rack controller for the R FR 3010 rack frame
R CT 5010	Rack Bus Extension for R FR 3010 rack frame. In combination with R CT 5020
R CT 3000	Service Adapter for remote configuration of one MiniModule via PC or Palm

Parts List

Due to the very dense design and high level of integration there are no user serviceable electronic assemblies within the D VD 3120 module.

D VA 3120 Mini Module (complete)

Description	Dist Amp Dig Video
Model Number	D VA 3120
Part Number	6.155.002.270

Service

If you are experiencing problems, or have questions concerning your D VA 3120 MiniModule please contact your local distributor for assistance.

We offer a fixed cost service exchange program for defective Series 3000 MiniModules out of Warranty. Please contact your distributor or check our web site for details on this program.

More detailed product information and product updates may be available on our web site:

www.lynx-technik.com

You will also find links to contact us directly for assistance.

Contact Information

Please contact your local distributor; this is your local and fastest method for obtaining support and sales information.

LYNX Technik can be contacted directly using the information below.

Address	LYNX Technik AG Brunnenweg 3 64331 Weiterstadt Germany
Website	www.lynx-technik.com
E-Mail	info@lynx-technik.com

LYNX Technik manufactures a complete range of high quality modular products for broadcast and Professional markets, please contact your local representative or visit our web site for more product information.



